

RM Mini Slide

with optional position monitoring
 double acting, max. operating pressure 500 bar

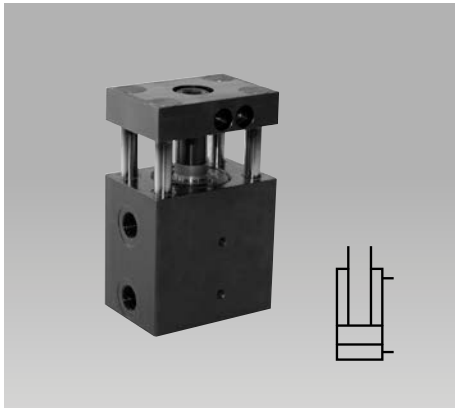

Description

The RM mini slide is a compact block cylinder with 4 integrated guide rods which are also in the position to compensate side loads and moments.

Threads can be provided in the front block for fixing of the working loads or tools (see page 4). To avoid a possible point of squeezing between the front block and the cylinder the safety distance of 25 mm as per DIN EN 349 is maintained.

The RM mini slides can certainly be delivery equipped with position monitoring by limit switches or inductive sensors (see page 6).

Advantages

- 4 sizes each with 3 stroke lengths
- Compact block design
- 2 fixing possibilities
- 2 connecting possibilities
- 2 connecting possibilities
- Guide rods made of nitriding steel
- Safety distance against squeezing of fingers
- Optional position monitoring with limit switches or inductive sensors
- Standard FKM-seals
- Temperature range -20...+150 °C
- Maintenance free

Areas of application

- Tool manufacture
- Mould making
- Metal forming
- Pressing
- Punching
- Deburring
- Perforating
- Power workholding
- Assembly technology

Important notes

The RM mini slide must never be operated with the delivered front block only, i.e. without working load (see application example).

Reason: In order to spare overall length, the guide rods with collar are plugged in from the front into the counterbores of the front block. Locking in the other direction has to be effected by the screwed on working load (tool fixing plate). All 4 counterbores have to be covered at least partially (see page 4).

The safety distance of 25 mm between the front block and the cylinder has to avoid squeezing of the fingers. A complete protection is however only possible by mounting further safety devices, which is the responsibility of the machine tool manufacturer.

If the RM mini slide is secured so that injuries of the operator are excluded even in the setting mode, the distance bushing between the front block and the piston rod can be removed. The total length is reduced by 15 up to 18 mm (dimension c1).

The RM mini slide has to be efficiently protected against swarf, aggressive coolants and welding spatter.

Operating conditions, tolerances and other data see data sheet A 0.100.

See also recommendations on page 5.

Fixing possibilities

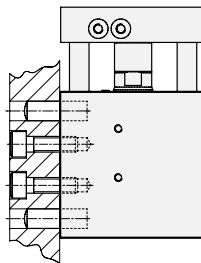

Connecting possibilities

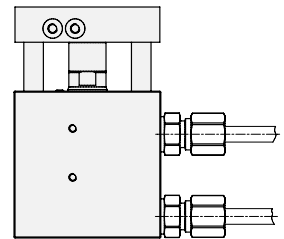

Cylinders must be backed up for operating pressures exceeding 100 bar or secured by dowel pins.

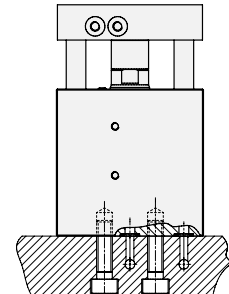
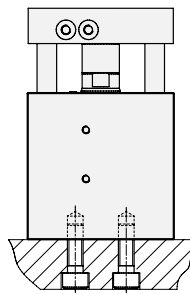

Application example for deburring tools

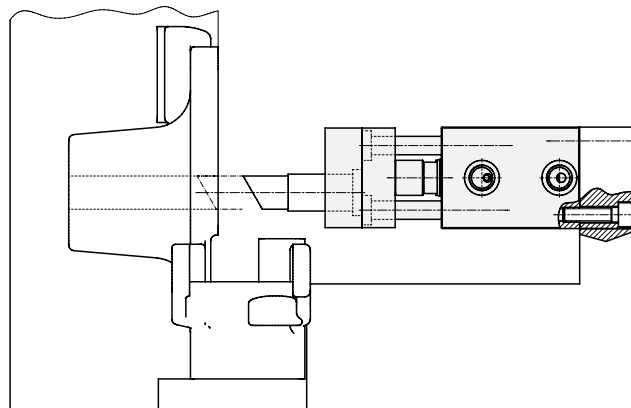

Technical data and dimensions

Versions with connecting thread

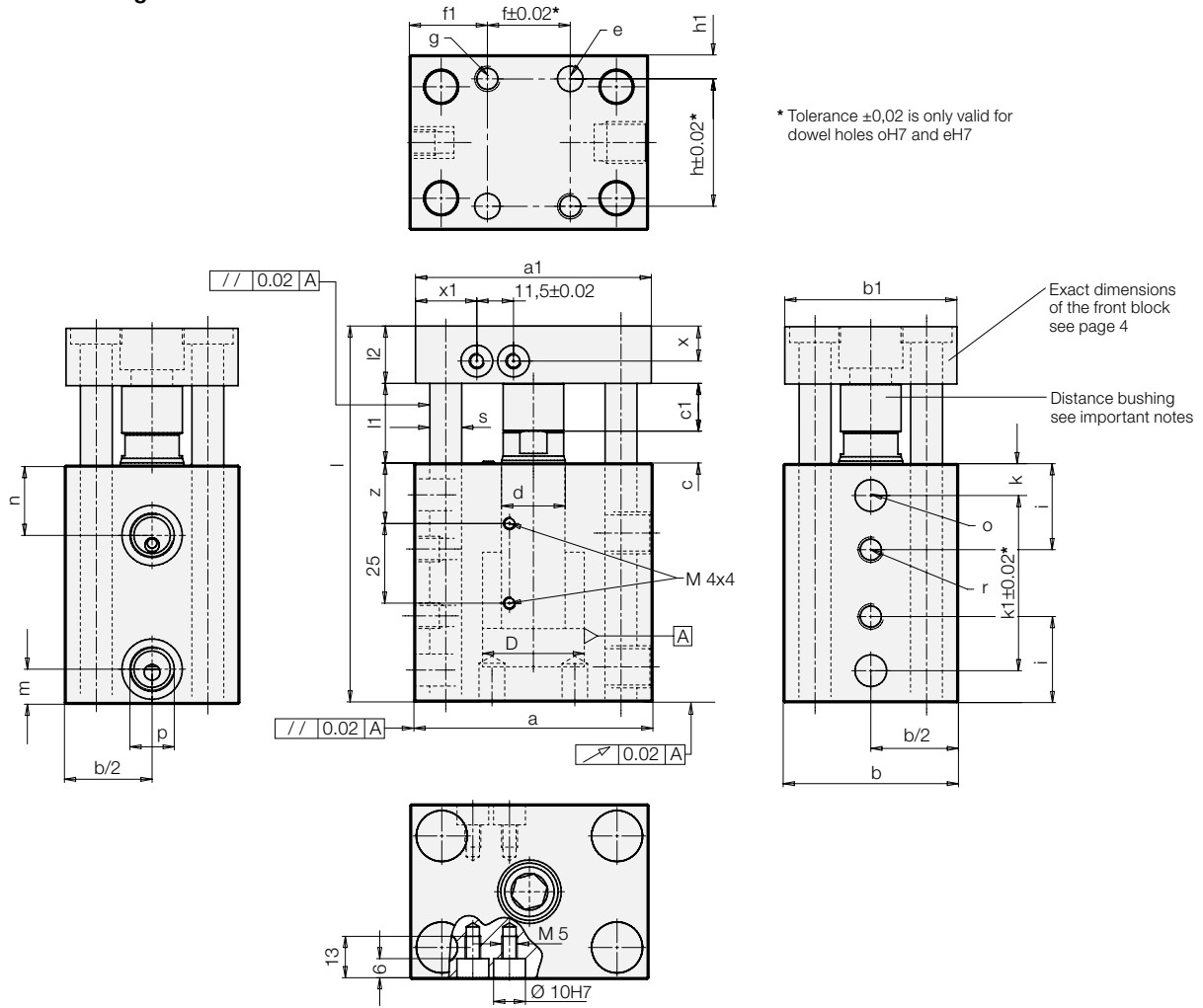

Version for manifold mounting with O-ring sealing

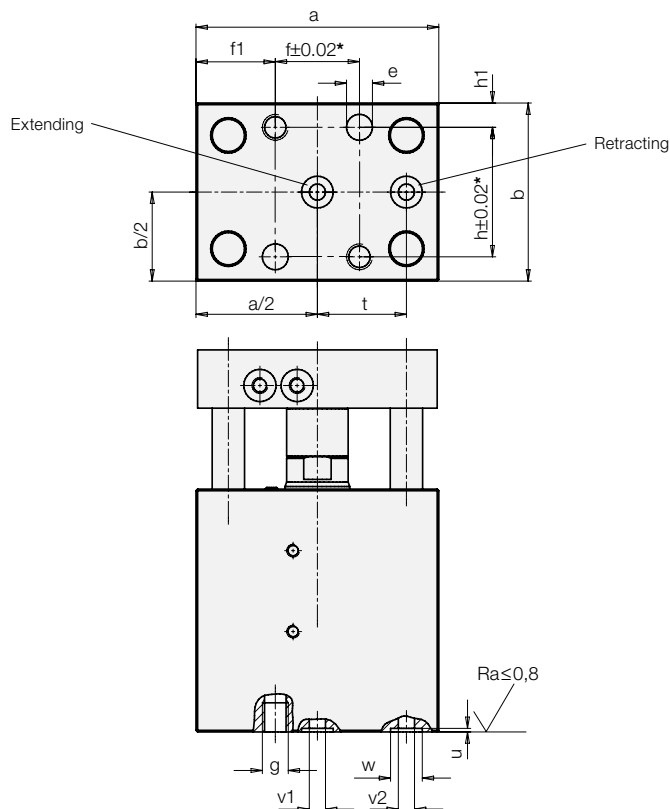

Part numbers

Piston Ø D		[mm]	25	32	40	50
Rod Ø d		[mm]	16	20	25	32
Force to push at	100 bar	[kN]	4.9	8	12.6	19.5
	500 bar	[kN]	24.5	40.2	62.8	98.5
Force to pull at	100 bar	[kN]	2.9	4.9	7.7	11.6
	500 bar	[kN]	14.5	24.5	38.3	57.9
Oil volume per	Stroke to extend	[cm ³]	4.91	8.05	12.56	19.63
10 mm stroke	Stroke to retract	[cm ³]	2.9	4.9	7.7	11.6
a		[mm]	65	75	85	100
a1		[mm]	64	74	84	99
b		[mm]	45	55	63	75
b1		[mm]	44	54	62	74
c		[mm]	7	10	10	10
c1		[mm]	18	15	15	15
e		[mm]	8H7x8 deep	8H7x8 deep	10H7x10 deep	12H7x12 deep
f		[mm]	26	26	33	40
f1		[mm]	19.5	24.5	26	30
g		[mm]	M8x9	M8x9	M10x10	M12x12
h		[mm]	32	40	48	57
h1		[mm]	6.5	7.5	7.5	9
i		[mm]	24	27	28	34
k		[mm]	10	10	11	14
k1		[mm]	24 + stroke	30 + stroke	32 + stroke	37 + stroke
l1		[mm]	25	25	25	25
l2		[mm]	15	18	25	28
m		[mm]	11	11	11	13
n		[mm]	18	22	24	27
o		[mm]	8H7x8 deep	10H7x10 deep	12H7x10 deep	16H7x13 deep
p			G 1/4	G 1/4	G 1/4	G 1/4
r		[mm]	M 8x8	M 8x8	M 10x10	M 12x12
s		[mm]	8	10	12	16
t		[mm]	25	27.5	31.5	38
w +0.2		[mm]	9.8	9.8	9.8	10.8
u ±0.05		[mm]	1.1	1.1	1.1	1.1
v1 extend		[mm]	4	5	6	6
v2 retract		[mm]	4	4.5	4.5	6
z ±0.2		[mm]	25	19	22	32
Dimensions O-ring			7x1.5	7x1.5	7x1.5	8x1.5
Part no. O-Ring (FKM)			3001077	3001077	3001077	3000275

Part no. double acting with connecting thread

Stroke ±1	[mm]	20	25	25	25
Total length l ±1	[mm]	104	118	129	143
Weight	[kg]	1.6	2.8	4.1	6.4
Part no.		RM302010	RM402510	RM502510	RM602510
Stroke ±1	[mm]	50	50	50	50
Total length l ±1	[mm]	134	143	154	168
Weight	[kg]	2.2	3.7	5.1	7.8
Part no.		RM305010	RM405010	RM505010	RM605010
Stroke ±1	[mm]	100	100	100	100
Total length l ±1	[mm]	184	193	204	218
Weight	[kg]	3.8	5.5	7.1	10.8
Part no.		RM310010	RM410010	RM510010	RM610010

Temperature range -20...+150 °C

For versions with position monitoring consider environmental temperature of the switches indicated on page 6.

Bestellnummerschlüssel:

RMXXX10 - version without position monitoring

RMXXX11 - version with 1 inductive sensor at the right side

RMXXX12 - version with 2 inductive sensors at the right side

RMXXX13 - version with 1 limit switch at the right side

RMXXX14 - version with 2 limit switches at the right side

RMXXX15 - version with 1 inductive sensor at the left side

RMXXX16 - version with 2 inductive sensors at the left side

RMXXX17 - version with 1 limit switch at the left side

RMXXX18 - version with 2 limit switches at the left side

Versions for manifold mounting with O-ring sealing at the bottom (O-rings are included in the delivery).

RMXXXXXB

Dimensioning of the front block Position of the position monitoring

Dimensioning of the front block

To fix the working load (tool fixing plate) threads and possibly dowel holes have to be provided in the front block. The exact dimensioning of the front plate facilitates their arrangement so that a collision with existing bore holes can be avoided.

The tool fixing plate has to cover at least partially the 4 counterbores.

	RM3	RM4	RM5	RM6
a1	64	74	84	99
a2	48	55	61	74
b1	44	54	62	74
b2	28	35	38	45
l2	15	18	25	28
t1	5	5	7	7
t2	11	13	18	22
m1	10.5	13	17	21
m2	18	20	26	33
s	8	10	12	16
s1	14	16	18	22
x	9	11	12	11
x1	19.25	19.25	21.25	24.25
Weight [kg]	0.25	0.44	0.80	1.20
Part no.	3538568	3538569	3538570	3538571

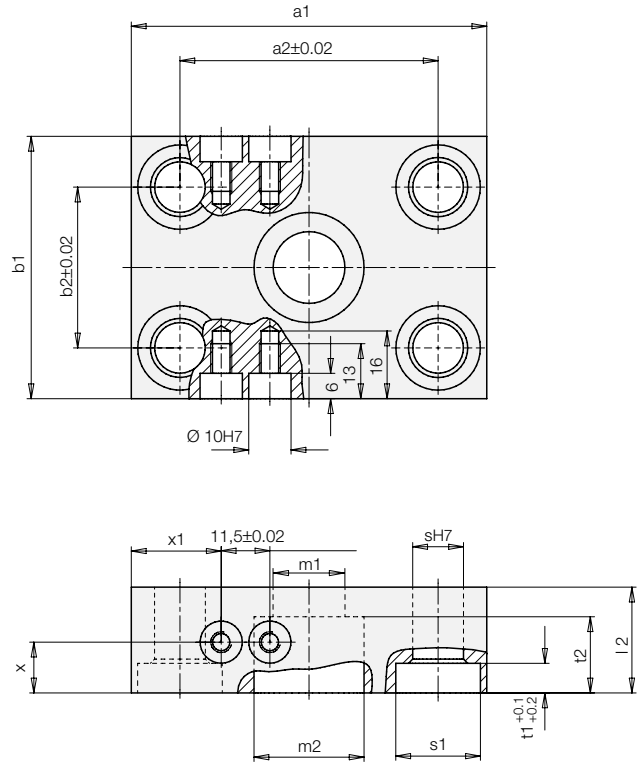

Position of the position monitoring

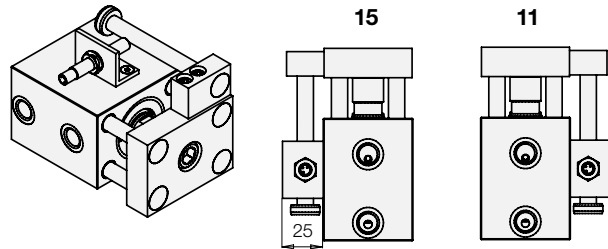

Single inductive monitoring

RMXXX11 = monitoring at the right side
RMXXX15 = monitoring at the left side

The switching point is selectable by displacing the control cam on the switch rod.

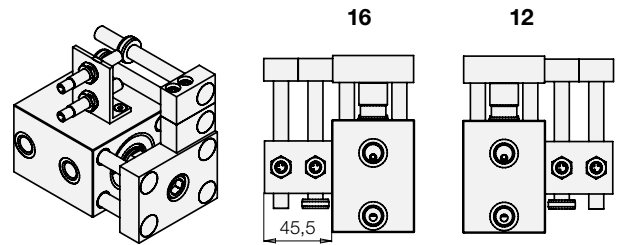

Double inductive monitoring

RMXXX12 = monitoring at the right side
RMXXX16 = monitoring at the left side

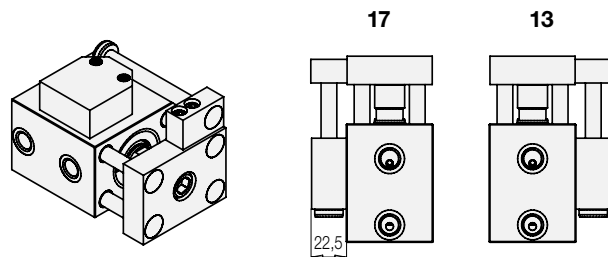

Single limit switch monitoring

RMXXX13 = monitoring at the right side
RMXXX17 = monitoring at the left side

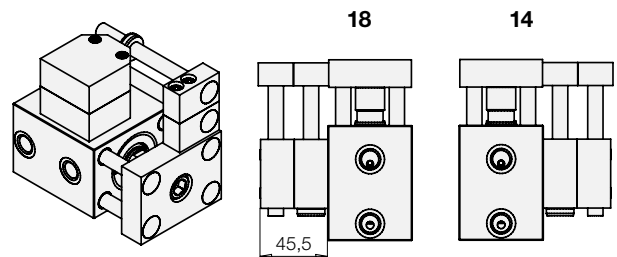

Double limit switch monitoring

RMXXX14 = monitoring at the right side
RMXXX18 = monitoring at the left side

Moments and side loads Recommendations

Maximum side load F as a function of the stroke

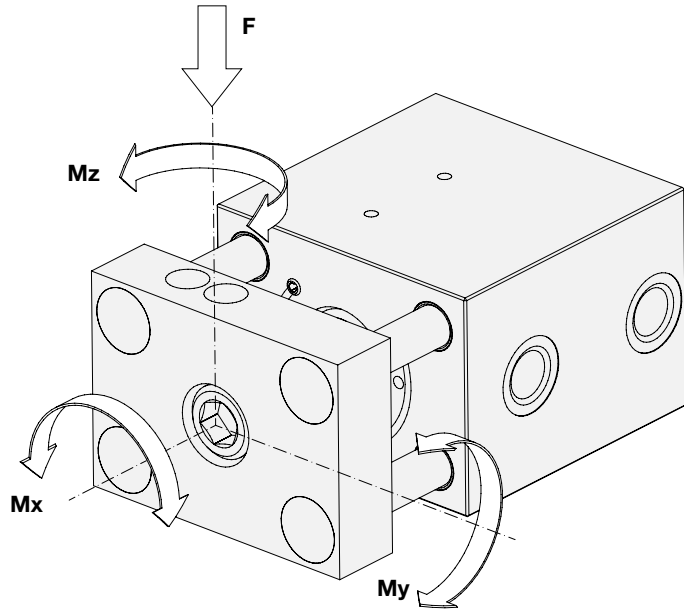
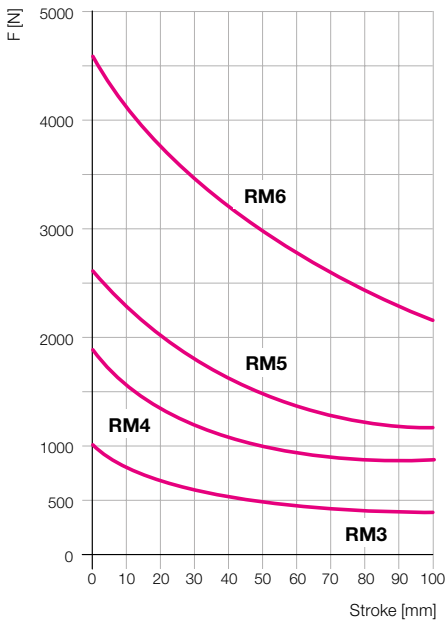

Recommended maximum moments as a function of the stroke

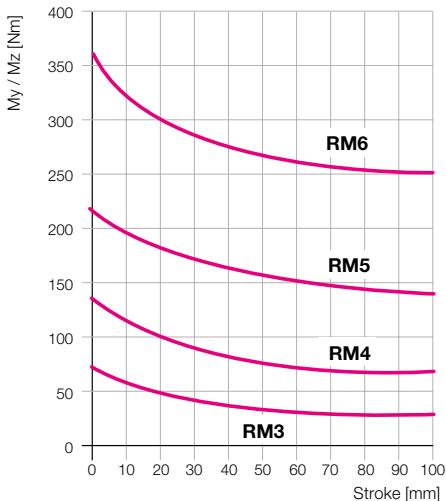
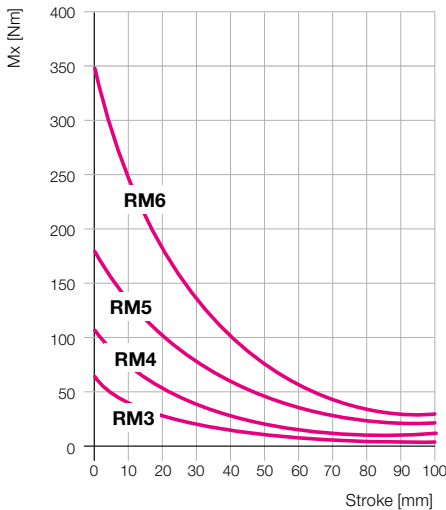

Load of the front block

If the front block is loaded with side loads and moments, guide rods will be deformed. This deformation is as bigger as longer the stroke. The following assumptions are valid for the maximum moments and side loads recommended in the diagrams:

1. Moment M_x must distort the front block by maximally 0.1 mm.

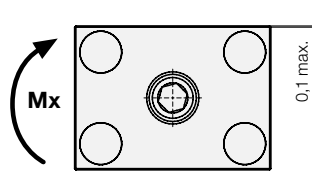

2. The moments M_y or M_z may tilt the front block by maximally 0.1 mm.

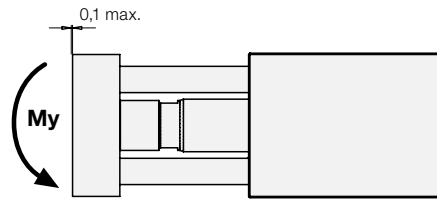

3. The maximum side load F must not exceed the admissible load of the rod guide.

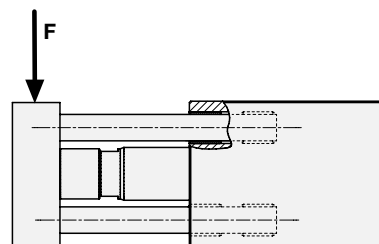

The maximum side load as per diagram utilizes the whole capacity of the guide rods regardless of their deflection. For the recommended moments a limit value of 0.1 mm is assumed. Certainly the system will withstand considerably higher values, but the deformations are no longer acceptable in applications. Here the RM mini slide reaches its limits.

Recommendations:

1. Introduce the forces in the centre of the guide plate to use the force potential of the RM mini slide.
2. Select the cylinder stroke as short as possible.
3. Keep the working load (tool weight) as low as possible.
4. The RM mini slide has no stroke end cushioning. Therefore do not use the whole stroke, but push the tool against an external stop. This is above all indicated for high loads and/or high piston speed.

Technical data Inductive sensor • Limit switch

Inductive sensor

General data

Type of installation	flush mounting
Rated operating distance S_n	[mm] 1,5
Secured operating distance S_a	[mm] 0...1.2
Repeatability	[%] ≤ 5
Hysteresis	[%] ≤ 15
Environmental temperature	[°C] -25...+70
Degree of contamination	3
Stand-by delay	[ms] ≤ 10

Mechanical data

Shape in mm	[mm] M 8
Material of the body	stainless steel
Material of sensing face	PBTP
Code class	[IP] IP 67
Connection	plug S49

Electrical data

Voltage	DC
Wiring	3 wires
Switching function	interlock
Output signal	pnp
Rated operating voltage	[V] 24 DC
Rated operating current	[mA] 200
Operating voltage U_b	[V] 10...30 DC
Residual ripple	% v. $U_b \leq 15$
Mains frequency	[Hz]
Switching frequency	[Hz] 3000
No-load current	[mA] $\leq 8/\leq 1$
Voltage drop	[V] $\leq 1,5/-$
Short circuit protection	yes
Protection against reverse battery	yes

Part no. 3829 164

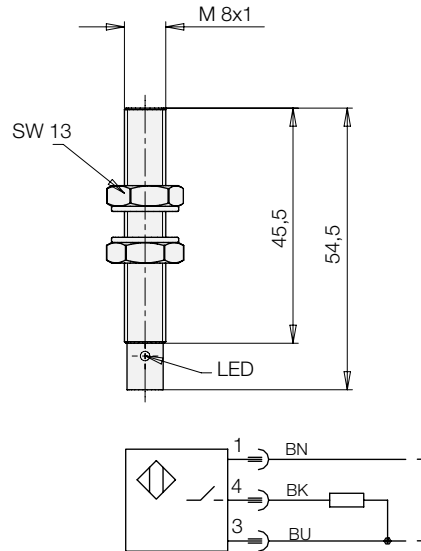

Accessories for inductive sensor

Connecting cable with right angle plug

Voltage	10 – 30 V DC
Protection as per DIN 40050	IP 67
Environmental temperature	-25 °C up to +90 °C
Plug connection	M8 plug
LED	Voltage (green) Function display (yellow)
Cable, length of cable	PUR, 5 m
Output, interlock	pnp npn
Part no. (1 off)	3829 099 3829 124

Limit switch

Material of the body	aluminium diecasting
Code class as per DIN 40050	IP67
Class as per VDE 0660 part 200	30x10 ⁶ mechanical switching examples
Environmental temperature	[°C] -5 up to +80
Switching principle	snap switch
Switching elements	1 make contact + 1 break contact
Connection	soldered connection
Cross section of the connection max.	[mm ²] 1
Make time	[ms] < 5
Bounce time	[ms] < 3
Max. switching frequency	[min ⁻¹] 200
Nominal switch off capacity	24V/2A
Switching voltage min.	[V] 12
Min. switching current at 12 V	[mA] 10
Short circuit protection (control fuse)	6A slow -10A fast

Bestell-Nr. 3829222

