

Hydro-Pneumatic Pump

max. operating pressure 500 bar



Application

The hydraulic clamping pump is particularly suitable for small to medium-sized clamping and mounting devices having single-acting cylinders which operate primarily by intermittence (pressure build-up and pressure holding).

Description

The tandem plunger pump is built into the oil reservoir in a space-saving manner. It operates with oscillating movements and automatic stroke reversal control by a pilot-operated 4/2 valve. The stroke frequency, and consequently the delivery flow rate depend on the air pressure and the hydraulic counterpressure.

Delivery flow rate without counterpressure

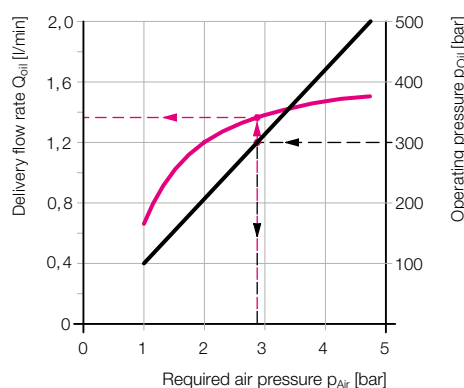

Example:

To get the operating pressure $p_{oil} = 300$ bar, an air pressure of $p_{Air} = 2.8$ bar is set on the pressure regulator. The delivery flow rate Q_{oil} without counterpressure is 1.35 l/min.

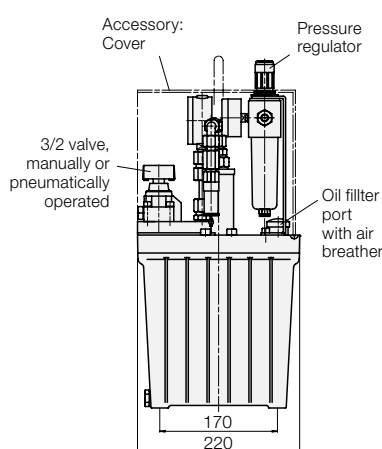

Control variants

Hand-operated 3/2 valve

This valve is equipped with a turning handle for direct operation on the unit.

Pneumatically operated 3/2 valve

This valve is mounted on the power unit allowing for pneumatic remote control, which, however, requires an additional hand lever valve (accessory). According to the length of the pneumatic piping between both valves, there is a longer or shorter time delay for the clamping and unclamping operation.

Without valve (external valve control)

This type is designed for external valve control connected with a pressure and return line each. The clamping pump keeps the set pressure constant.

A valve must never be used for depressurized circulation as the pump only serves for intermittent operation.

Technical data

Max. delivery flow rate	[cm ³ /s]	25
	[l/min]	1.5
Max. operating pressure	[bar]	500
Min. operating pressure	[bar]	100
Max. air pressure	[bar]	4.7
Min. air pressure	[bar]	1.0
Transmission ratio		1:108
Max. air consumption	[l/min]	1200
Min. control pressure for pneumatic valve	[bar]	3
Max. charge	[l]	4.0
Usable oil volume	[l]	1.8
Viscosity range	[10 ⁻⁶ m ² /s]	10...500
Recomm. viscosity grade as per DIN 51519		ISO VG 22
Recomm. hydraulic oil as per DIN 51524		HLP 22
Noise level	[dBA]	78
Weight	[kg]	20

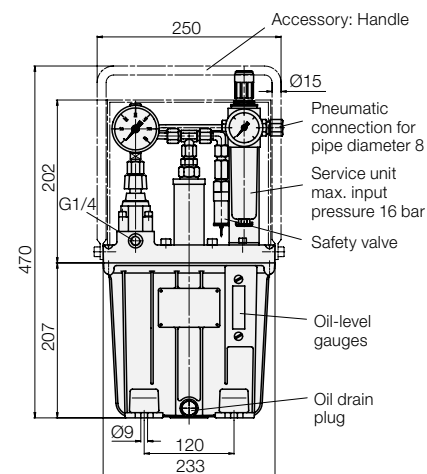

Delivery circuit

The units are delivered complete and ready for connection. On the pneumatic side there is a service unit with pressure reducer, and filter. And additional pressure relief valve prevents increase of pressure over 4.8 bar, and thus operating pressures over 500 bar on the hydraulic side.

Part no.

Pump with hand-operated valve	8600110
Pump with pneumatic valve	8600111
Pump without valve	8600112

Accessories

Handle	0353217
Cover	0353714

Accessory for pneumatic remote control of 8600111

Hand lever valve with catch	3812005
Sound absorber for hand lever valve	3887015
Foot valve with catch incl. cover	0381206
Air hose NB 6	3890059
Screwed socket G1/4	3890071
Hose clamp	3890076

Example for ordering



Pump with hand-operated valve	8600110
Handle	0353217
Cover	0353714

Operation:

Manually operated 3/2 valve

Part no. 8600110

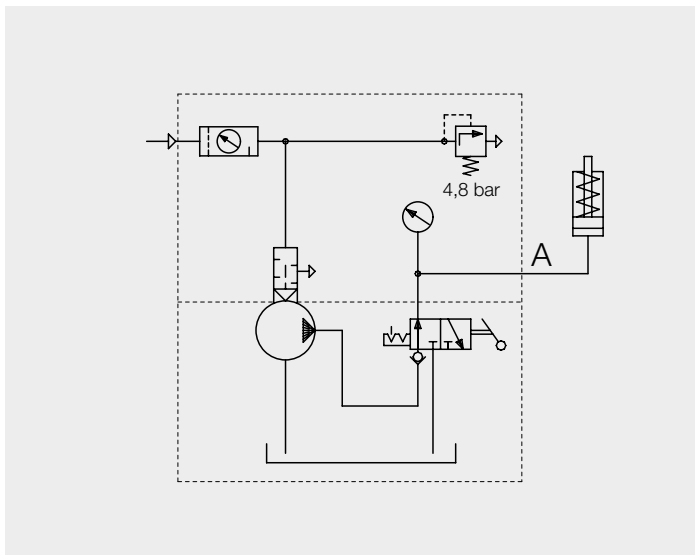

Operation:

Pneumatically operated 3/2 valve

Part no. 8600111

Accessory for pneumatic remote control
see page 1

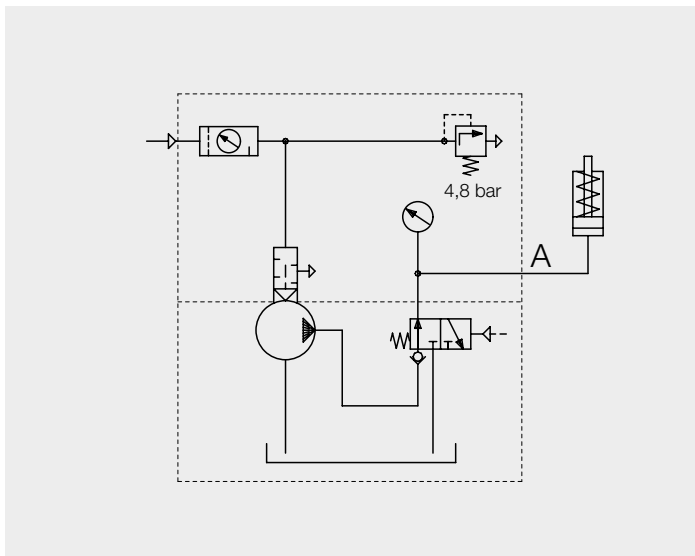

Operation

External valve control (remote control)

Part no. 8600112

