

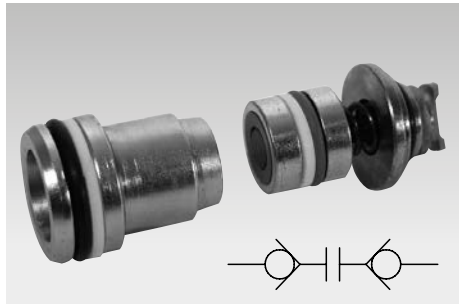

**Coupling Elements**

**Built-in type and threaded-body type**

**ND 3, ND 5, ND 8, max. operating pressure up to 500 bar**



**Built-in type**

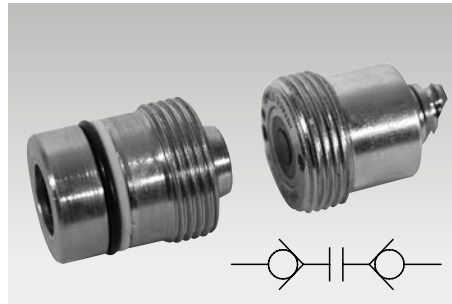

**Threaded-body type**

**Coupling situation**

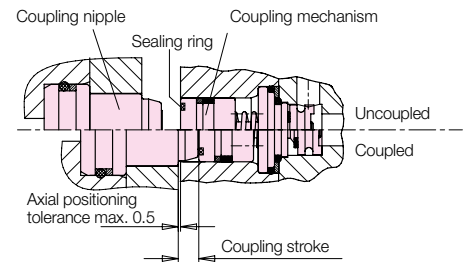

**Application**

On machine tools with pallet changing systems, the coupling elements transfer hydraulic oil or compressed air from the machine table to the hydraulic clamping fixture.

**Description**

The coupling mechanism and the coupling nipple are provided with axial seals (see coupling situation) and have a very short coupling stroke. The smooth front face of the coupling mechanism is easy to clean in case of swarf formation. The recessed sealing disk can be easily replaced with the assembly tool if it is damaged. The built-in type is fixed with an intermediate plate and is particularly suitable for multi-couplings (see also data sheet F 9.440). The intermediate plates (location plates or covers) must absorb the axial forces generated by the hydraulic pressure (see pages 2 and 3). In case of the threaded-body type, the coupling mechanism is screwed directly into the base plate and the coupling nipple into the clamping fixture. The coupling nipple with VSV (preloaded valve) should be installed in the unclamping or return line of the clamping fixture. The VSV limits a possible pressure build up to approx. 5 bar when uncoupled. Depending on the sealing, the coupling elements can be coupled either against pressure or only without pressure.

**Type with integrated nozzle**

A nozzle on the coupling mechanism generates a strong air stream to clean the smooth front face (see page 4).

**Advantages**

- Many installation variants
- Space-saving installation dimensions
- 3 different nominal diameters for optimum adaptation to the flow rate
- Built-in and threaded-body type of the same nominal size can be combined
- Transmission of hydraulic oil, compressed air and vacuum\*
- Stainless steel coupling elements
- Coupling mechanism with smooth front face reduces contamination and is easy to clean
- Axial sealing disk easily renewable
- Additional bushing simplifies the fabrication of the location hole for the coupling mechanism
- Relatively large positioning tolerances
- Threaded-body type ND 5 with integrated nozzle to clean the sealing surface (see also page 4)

**Important notes!**

The sealing surfaces on the front face of the coupling elements have to be cleaned before coupling to ensure the tightness in coupled condition. We recommend to wash the elements and finally clean them with compressed air. Protection covers should be used as far as possible.

The mounting bodies of the coupling elements must be guided in parallel 2–3 mm before coupling without exceeding the radial positioning tolerance.

To transmit compressed air and vacuum, use only the coupling elements for “depressurised coupling”.

\* Other media such as coolant and water on request.

**Coupling force**

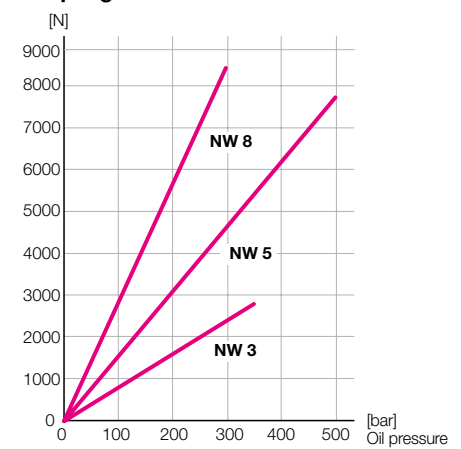

**Δ characteristic curve**

for kinematic viscosity of  $53 \times 10^{-6} \text{ m}^2/\text{s}$  (HLP 22 at 20 °C)

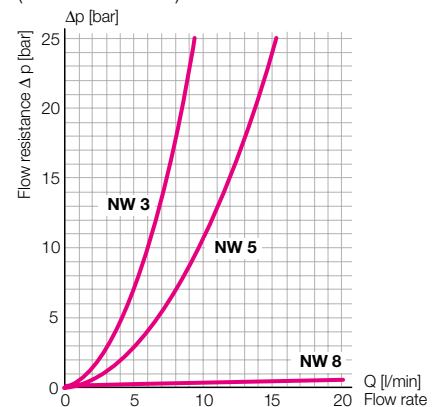

ND8:  $\Delta p = 1.75 \text{ bar}$  at 35 l/min

**General technical characteristics**

Type	Threaded-body	Built-in	Threaded-body	Threaded-body with nozzle	Built-in	Threaded-body	Built-in
Nominal diameter	3	3	5	5	5	8	8
Max. operating pressure [bar]	350	300	500	500	300	300	300
Max. flow rate [l/min]	8	8	12	12	12	35	35
Coupling stroke [mm]	4.5	4.5	4.5	4.5	4.5	7.4	7.4
Axial coupling force against pressure per coupling point [N]	F = 7.9 x p [bar]		F = 15.4 x p [bar]			F = 28.4 x p [bar]	
Axial coupling force at 0 bar [N]	60	60	90	90	90	105	105
Axial positioning tolerance [mm]	+0.5	+0.5	+0.5	+0.5	+0.5	+0.5	+0.5
Radial positioning tolerance [mm]	±0.1	±0.1	±0.25	±0.2	±0.2	±0.2	±0.2
Radial positioning tolerance for 0460776 / -751 [mm]	-	-	±0.5	-	-	-	-
Adm. angular deviation [°]	1	1	1	1	1	1	1

# Coupling nipple

Threaded-body type

## Installation examples

## Location hole

## Dimensions

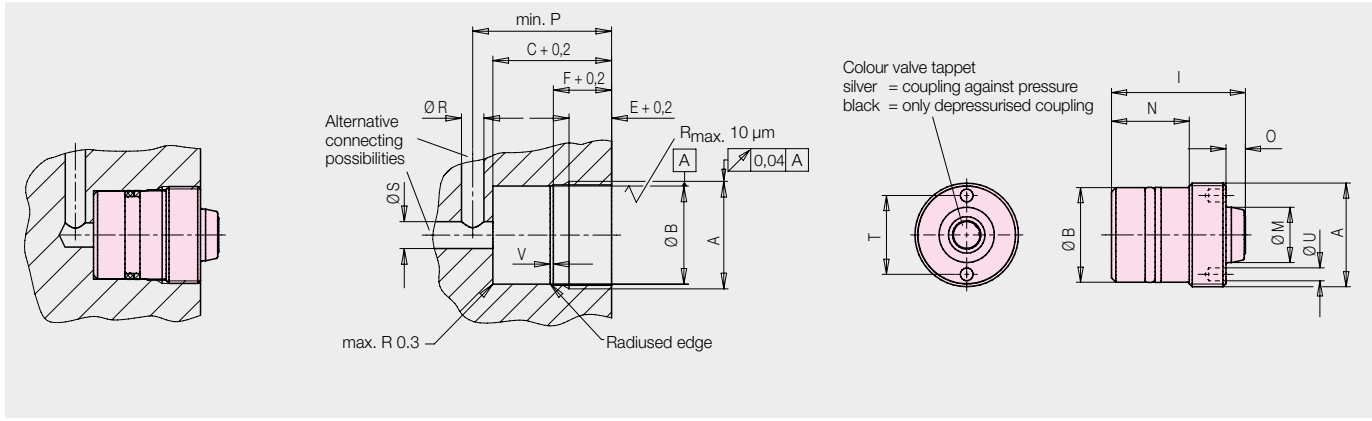

Built-in type

Holding force for cover > axial force A

## Base plate

## Cover

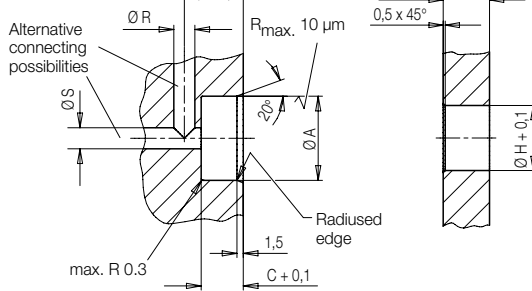
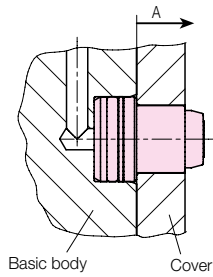

Colour valve tappet  
silver = coupling against pressure  
black = only depressurised coupling

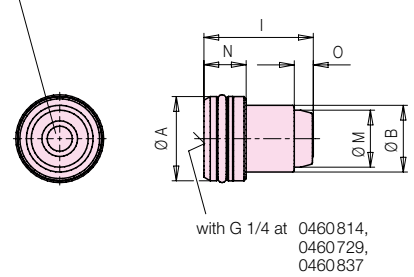

Type		Built-in	Threaded-body	Threaded-body with VSV	Built-in	Built-in long	Threaded-body	Threaded-body with VSV	Built-in	Threaded-body
ND		3	3	3	5	5	5	5	8	8
A	[mm]	Ø20 H7	M20x1.5	M20x1.5	Ø20 H7	Ø20 H7	M24x1.5	M24x1.5	Ø24 H8	M32x1.5
Ø B	[mm]	15.8	17 H7	17 H7	15.8	15.8	21.9 H8	21.9 H8	21	24 H7
C	[mm]	10	22	27.5	10	16.5	26.5	27.5	9	24
D	[mm]	11.5	-	-	11.5	17.1	-	-	15	-
E	[mm]	-	9.5	9.5	-	-	9.5	9.5	-	12.5
F	[mm]	-	11	11	-	-	13	13	-	15
Ø H	[mm]	16	-	-	16	16	-	-	21 H8	-
I	[mm]	25.9	26.5	32	25.9	38.1	31	32	31.4	31.4
Ø M	[mm]	9.8	9.8	9.8	13.5	13.5	12.8	13.5	18.4	18.4
N	[mm]	10	13.5	19	10	16.5	18	19	9	12
O	[mm]	4.5	4.5	4.5	4.5	4.5	4.5	4.5	7.4	7.4
P	[mm]	14	27	32	14	21	31	32	14	29
Ø R	[mm]	5	5	5	5	5	5	5	8	8
Ø S	[mm]	5	6	6	5	5	6	6	10	10
T	[mm]	-	15	15	-	-	18.25	18.25	-	24.6
Ø U	[mm]	-	2.8	2.8	-	-	2.8	2.8	-	4.3
V	[°]	-	1.5x20°	1.5x20°	-	-	0.7x15°	0.7x15°	-	2x20°
Axial force A	[N]	31.4xp [bar]	-	-	31.4xp [bar]	31.4xp [bar]	-	-	45.2xp [bar]	-
Tightening torque	[Nm]	-	37	37	-	-	40	40	-	45
<b>Part no.</b>										
<b>coupling against pressure</b>		<b>0460692</b>	<b>0460836</b>	-	<b>0460691</b>	<b>0460814</b>	<b>0460831</b>	-	<b>0460714</b>	<b>0460713</b>
<b>only depressurised coupling</b>		<b>0460743</b>	<b>0460838</b>	-	<b>0460682</b>	<b>0460729</b>	<b>0460751</b>	-	<b>0460841</b>	<b>0460772</b>
<b>with preloaded valve (VSV)*</b>		-	-	<b>0460834</b>	-	<b>0460837</b>	-	<b>0460835</b>	-	-
<b>Screw-in tool</b>		-	<b>2010905</b>	<b>2010905</b>	-	-	<b>2010904</b>	<b>2010904</b>	-	<b>2010903</b>

\* approx. 5 bar, only depressurised coupling

# Coupling mechanism

Threaded-body type

## Dimensions

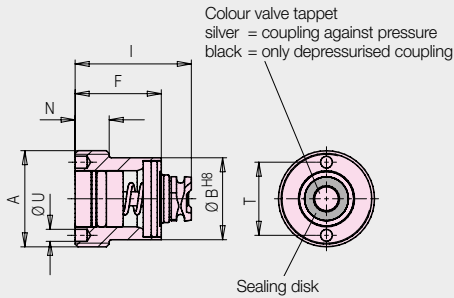

## Location hole

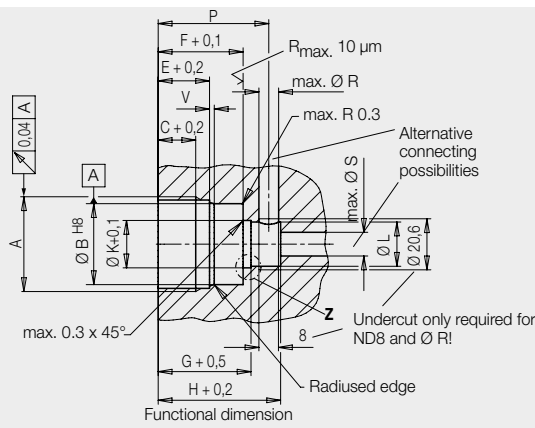

## Installation examples

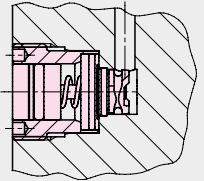

## Additional bushing for simple location hole

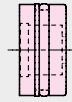

## Simple location hole

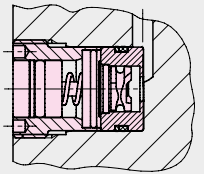
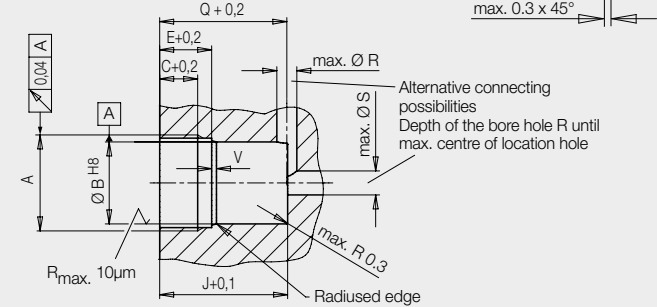

Built-in type

Colour valve tappet  
silver = coupling against pressure  
black = only depressurised coupling

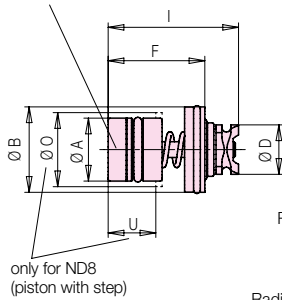

## Location plate for ND3 and ND5

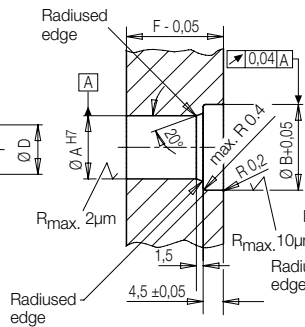

## Location plate only for ND8

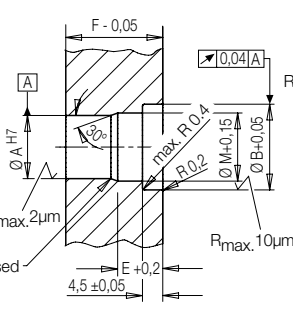

## Basic body

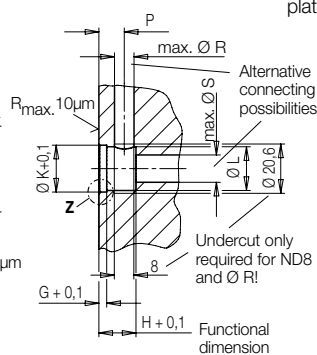

## Holding force for location plate > axial force A

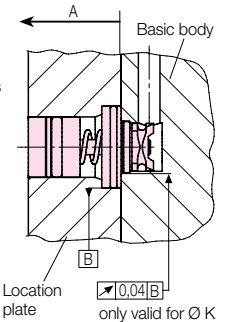

Type		Threaded-body	Built-in	Threaded-body	Built-in	Threaded-body	Built-in
ND		3	3	5	5	8	8
A	[mm]	M20x1.5	10	M24x1.5	14	M32x1.5	19
Ø B	[mm]	18 H7	15	20.5 H8	19	27 H7	24
C	[mm]	9.5	-	9.5	-	13	-
D	[mm]	-	10.8	-	10.8	-	18
E	[mm]	13	-	13	-	16	14
F	[mm]	21.5	21.5	21.5	21.5	31	31
G	[mm]	23.5	2	23.5	2	-	-
H	[mm]	31	9.5	31	9.5	46.5	15.5
I	[mm]	29.3	29.3	29.25	29.25	44	44
J	[mm]	32	-	32	-	49	-
Ø K	[mm]	12	12	12	12	-	-
Ø L	[mm]	11.2	11.2	11.2	11.2	18 H8	18 H8
Ø M	[mm]	-	-	-	-	-	20.5
N	[mm]	8.5	-	8.5	-	12	-
Ø O	[mm]	-	-	-	-	-	20
P	[mm]	28	6.5	28	6.5	38.5	7.5
Q	[mm]	31.8	-	31.8	-	48.8	-
Ø R	[mm]	5	5	5	5	8	8
Ø S	[mm]	6	7	6	7	8	10
T	[mm]	15	-	18.25	-	25	-
Ø U	[mm]	2.8	-	2.8	-	4.3	17.5
V	[°]	0.5x20°	-	2x20°	-	2x20°	-
Axial force A	[N]	-	17.7xp [bar]	-	28.4xp [bar]	-	45.2xp [bar]
Tightening torque	[Nm]	37	-	40	-	45	-
<b>Part no.</b>							
<b>coupling against pressure</b>		<b>0460832</b>	<b>0460818</b>	<b>0460830</b>	<b>0460656</b>	<b>0460711</b>	<b>0460712</b>
<b>only depressurised coupling</b>		<b>0460833</b>	<b>0460819</b>	<b>0460776</b>	<b>0460659</b>	<b>0460771</b>	<b>0460839</b>
<b>Additional bushing for simple location hole</b>		<b>0460884</b>	-	<b>0460777</b>	-	<b>0460847</b>	-
<b>Screw-in tool</b>		<b>2010905</b>	-	<b>2010904</b>	-	<b>2010903</b>	-
<b>Sealing disk (spare part)</b>		<b>3001997</b>	<b>3001997</b>	<b>3001999</b>	<b>3001999</b>	<b>3001998</b>	<b>3001998</b>
<b>Assembly tool for sealing disk</b>		<b>0460991</b>	<b>0460991</b>	<b>0460873</b>	<b>0460873</b>	<b>0460914</b>	<b>0460914</b>

## Threaded-body type with integrated nozzle Application example

**Coupling nipple ND5 threaded-body type part-no. 0460 703**  
for coupling mechanism with integrated nozzle

**Coupling against pressure**

Installation example

Location hole

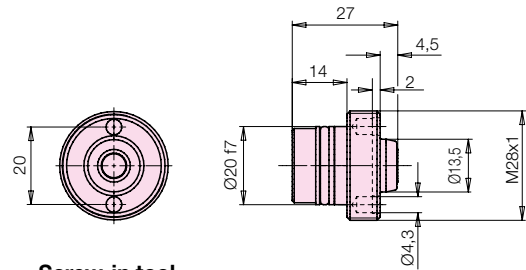
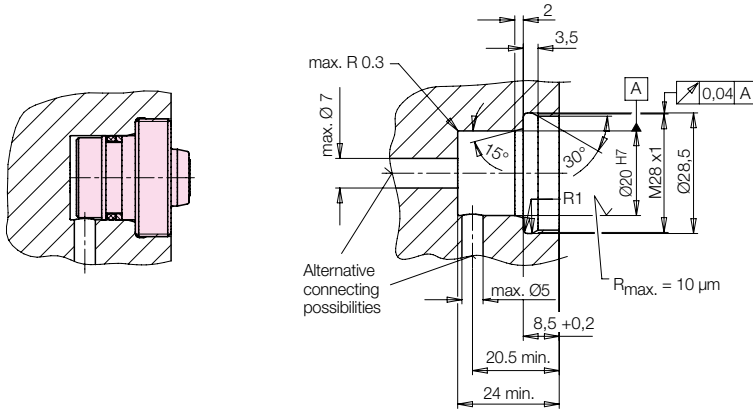

**Screw-in tool**  
**Part no. 2010901**

Tightening torque: 45 Nm

**Coupling mechanism ND5 threaded-body type part-no. 0460 732**  
with **integrated nozzle** to clean the sealing surface

**Coupling against pressure**

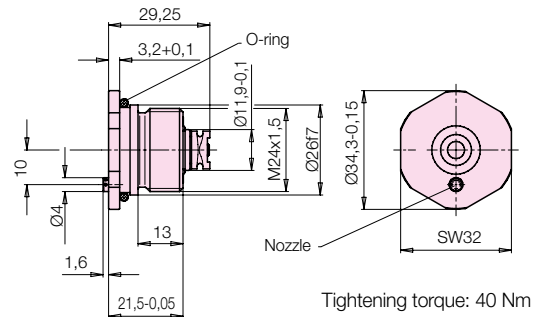
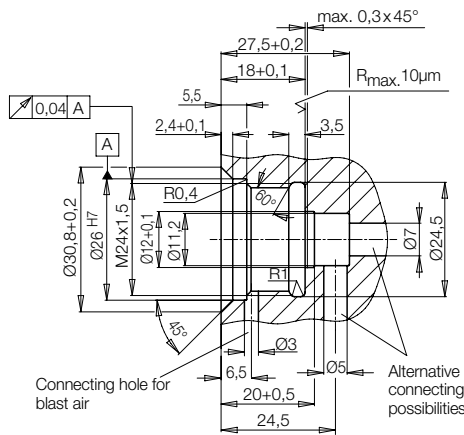
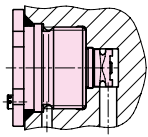

Tightening torque: 40 Nm

**Application example**  
**Rotary indexing table - clamping fixture, hydraulically operated, with trunnion bearing and hydraulic positioning**

