

Fixture clamp with fixed jaw

max. clamping force 15 kN, jaw width 65 mm,
 double acting, max. operating pressure 250 bar

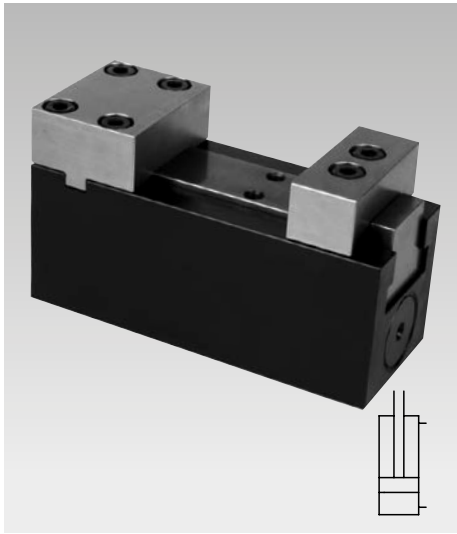

Advantages

- Very compact design
- High rigidity and precision
- Strokes 5 and 45 mm
- Double-acting function
- Fixtures without tubes possible
- Exchangeable jaws
- Pneumatic contact or seat control in the fixed jaw possible
- Good swarf protection
- Port for central lubrication
- Mounting position: variable

Function

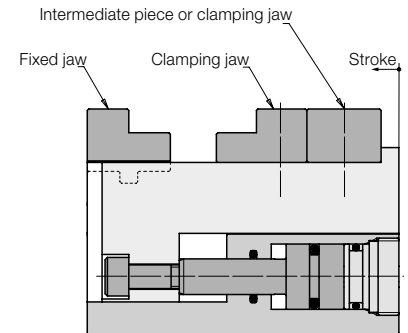

Application

The fixture clamps are used for machining of dimensionally stable workpieces in single or multiple clamping fixtures.

Due to their compact design they can be arranged in a very limited space.

Fixture clamps are especially suitable for series manufacturing in automated mode.

The double-acting cylinder function combined with central lubrication and good swarf protection guarantees a high process safety.

Fixing from above

with accessory adaptor plate

Drilled channels

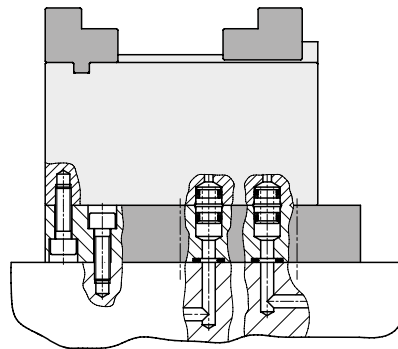

Fixing from below

Drilled channels

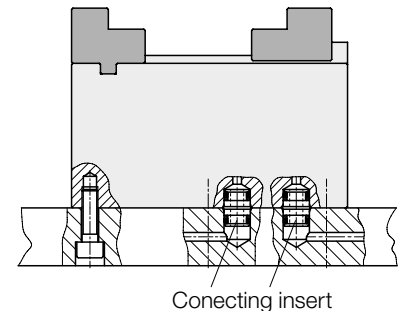

Description

The fixture clamp with fixed jaw consists of a very small basic body with integrated hydraulic cylinder which actuates the movable jaw.

All threads and ports are at the bottom to allow a space-saving arrangement of several clamping points in a very limited space.

If fixing from below is not possible an adaptor plate for manifold mounting or tube connection is available. As accessory also blanks of clamping jaws are available for adaptation to the workpiece contour.

The fixed jaw can be equipped with a pneumatic seat control.

Fitting connection

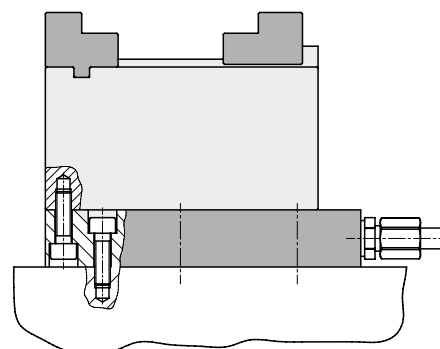

Accessories

Fixed jaw, clamping jaws and adaptor plate are not included in the delivery of the fixture clamp and have to be ordered separately as accessory.

Application example

Clamping fixture for a pedal of a freight vehicle.

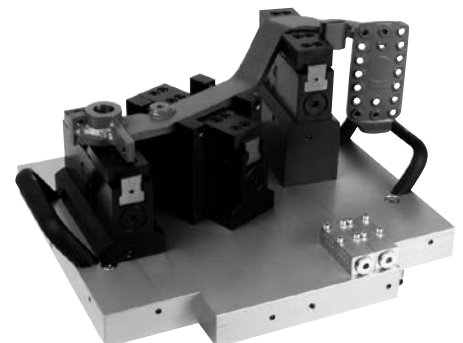

Important notes

The fixture clamp is only suitable for exterior clamping.

Lubricate at the latest after 500 clamping cycles the clamping slide via the central lubrication.

Never use the complete clamping stroke to guarantee safe clamping of the workpiece.

Max. operating temperature 80 °C.

Operating conditions and other data see data sheet A 0.100.

Clamping stroke 5 mm
Technical data • Accessories • Dimensions

Part no. 4413101

Technical data

Clamping force max.	[kN]	15
Clamping stroke	[mm]	5
Jaw width	[mm]	65
Max. flow rate	[cm ³ /s]	40
Stroke volume	[cm ³]	4
Clamping	[cm ³]	4
Unclamping	[cm ³]	3
Weight approx.	[kg]	5.05

Adaptor plate (accessory)

Weight approx.	[kg]	3.1
Part no.		0441310

Clamping force diagram

(Height of the clamping jaw 25 mm)

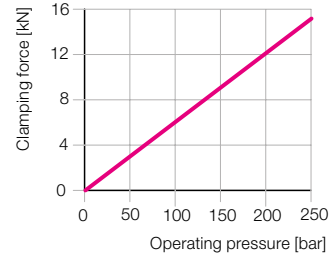

Accessory: adaptor plate

View from below

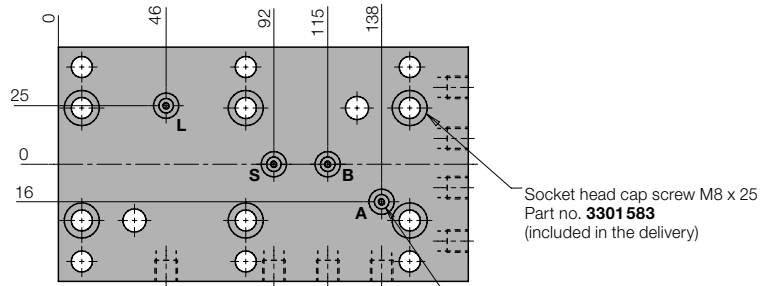

Clamping and unclamping

each Ø10 H7 x 7 deep for connecting insert **9210132** (included in the delivery), see also page F 9.300

Seat control and central lubrication with O-ring **3001842** (5x1 mm) (included in the delivery)

- A** = Clamping
- B** = Unclamping
- S** = Central lubrication
- L** = Air for seat control

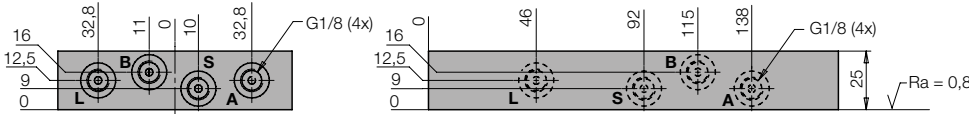
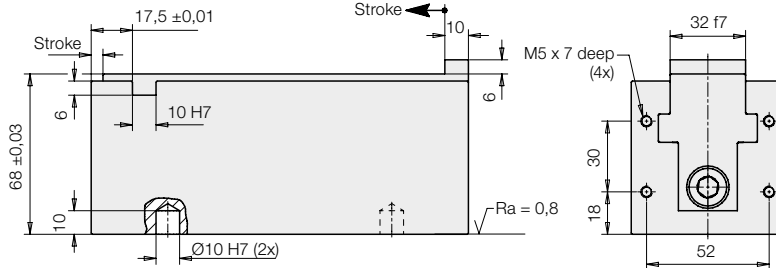
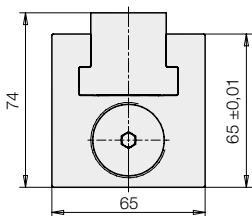
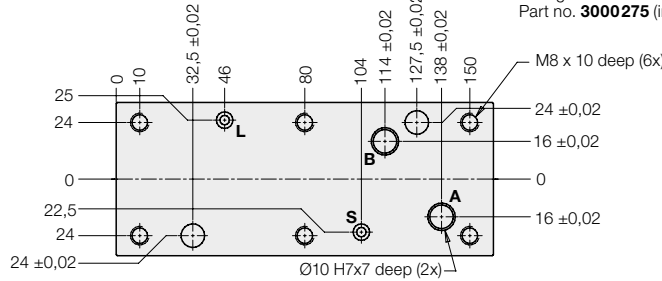

Accessory: adaptor plate

Side views

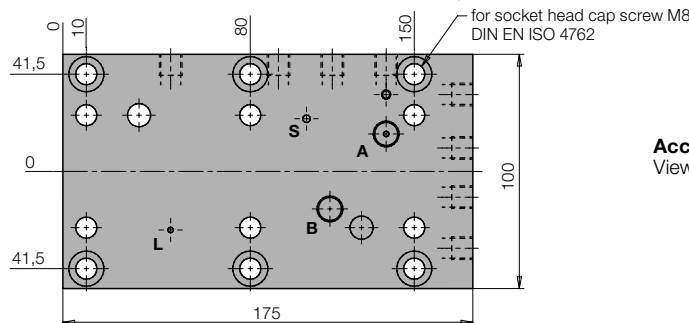
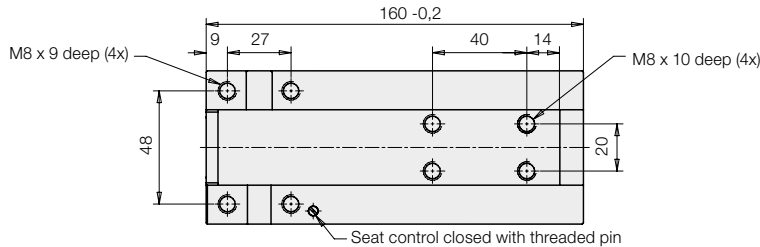

Accessory: adaptor plate

View from above

Clamping stroke 45 mm

Technical data • Accessories • Dimensions

Part no. 4413131

Technical data

Clamping force max.	[kN]	15
Clamping stroke	[mm]	45
Jaw width	[mm]	65
Max. flow rate	[cm ³ /s]	40
Stroke volume	Clamping [cm ³]	36
	Unclamping [cm ³]	27
Weight approx.	[kg]	ca. 7.0

Adaptor plate (accessory)

Weight approx.	[kg]	3.8
Part no.		0441313

Clamping force diagram
(Height of the clamping jaw 25 mm)

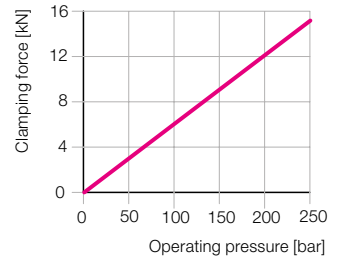

Accessory: adaptor plate
View from below

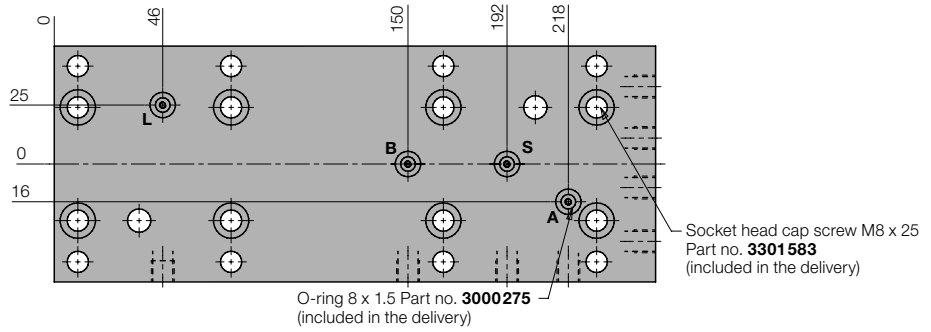

- A** = Clamping
- B** = Unclamping
- S** = Central lubrication
- L** = Air for seat control

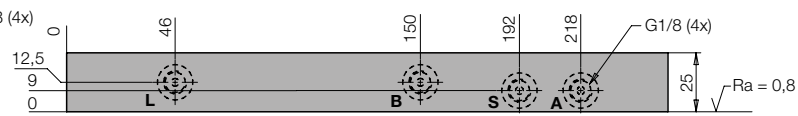
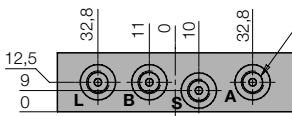
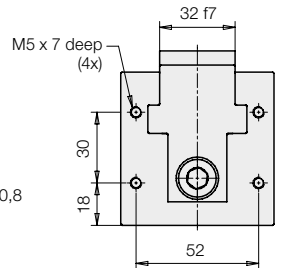
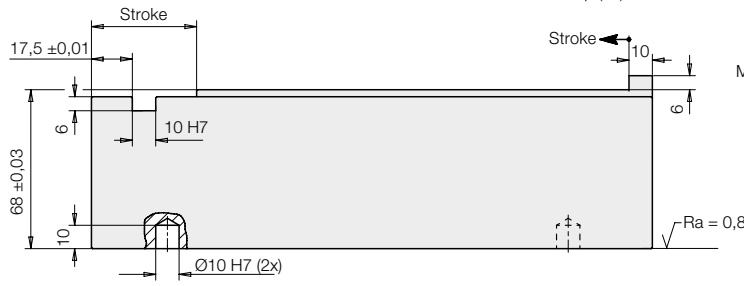
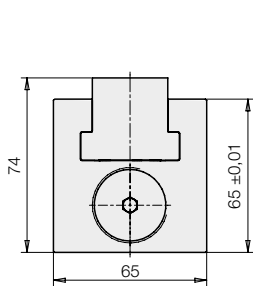
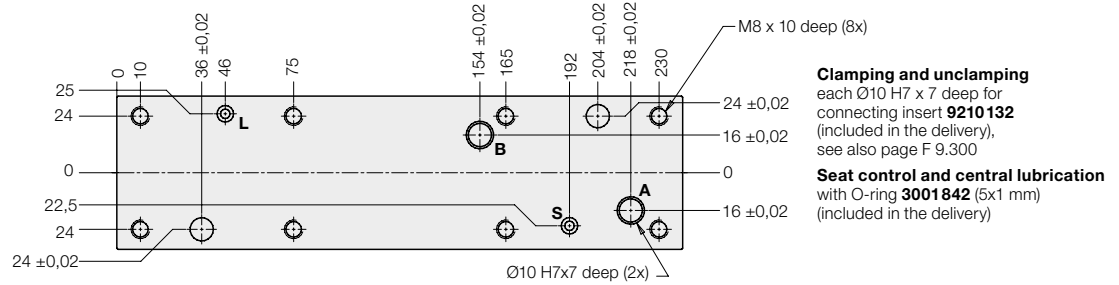

Accessory: adaptor plate
Side views

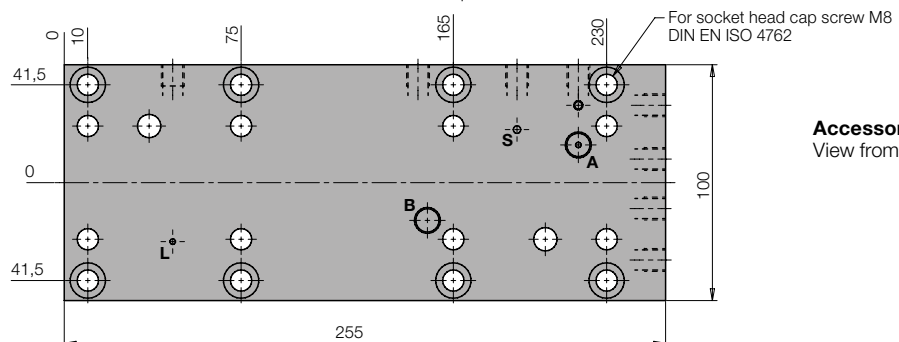
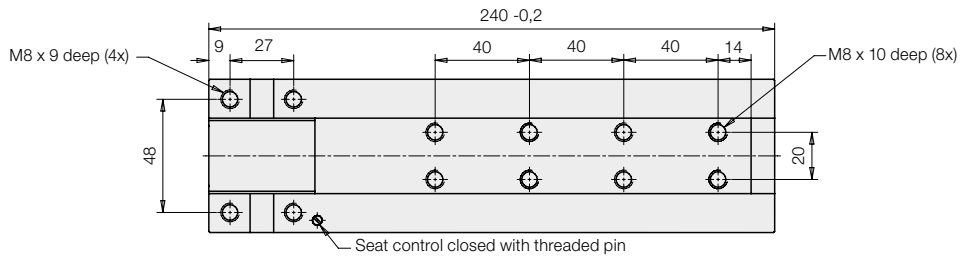

Accessory: adaptor plate
View from above

Accessory - clamping jaws

Versions: Clamping jaw blanks
 Material: 16 MnCr5 smooth

Clamping jaw: Part no. 3548080

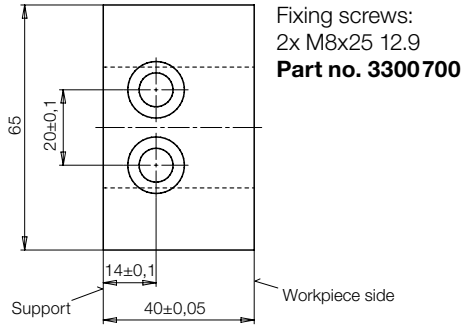
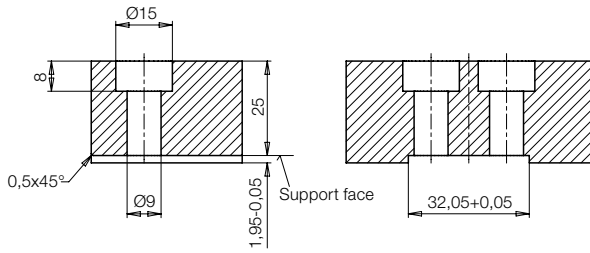

Fixed jaw: Part no. 3548081

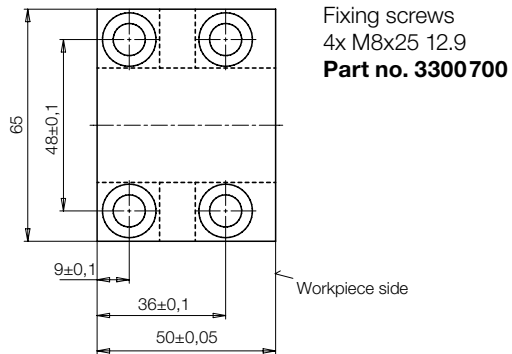
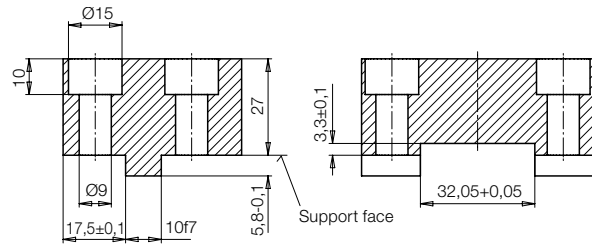

Self-made clamping jaws

Clamping jaws and fixed jaws are manufactured according to the contour of the workpiece to be clamped.

The max. height of the clamping jaw X at 250 bar operating pressure is indicated in the below chart.

If the operating pressure is lower, the clamping jaws and the fix jaws can be designed higher as per the below diagram.

Max. height of the clamping jaws X at max. operating pressure of 250 bar

Fixing screws for clamping jaws	M8x25 - 12.9
X [mm] with 2 screws	25
X [mm] with 4 screws	78

Max. height of the clamping jaw X as a function of the operating pressure

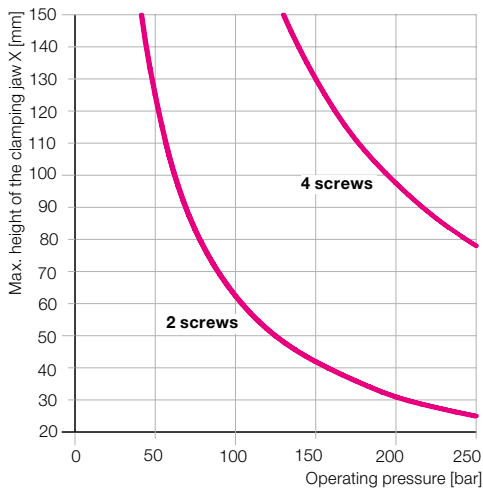

Important note

The clamping jaws must always be supported by the provided support, since the fixing screws are not in the position to compensate the generated clamping forces.

Fixing of the clamping jaws

