

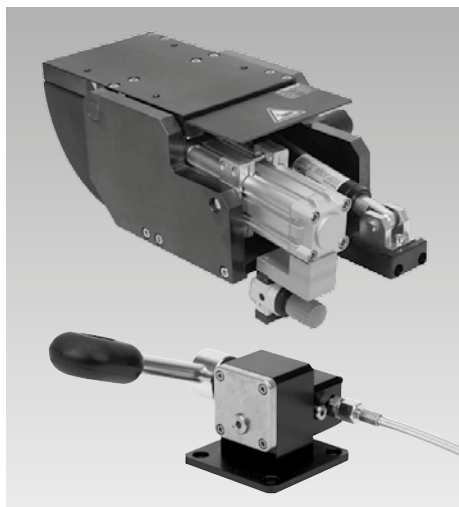

Tilting Module KMB 100

Max. load 1,000 N, load balanced manual operation



Advantages

- Easy tilting and fixing of components in angle positions 0° and 90°
- Compensation of the tilting torques by pneumatic balancer and brake cylinder
- Locking of individual tilting positions 0°/90°
- High load potential
- Suitable for table mounting
- Good accessibility from all sides
- Optimised ergonomics
- Easily combinable with other *modulog* modules

Application

Tilting module for universal use in assembly and handling processes in the industry.

Principal use

- Assembly of car seats
- Motor assembly
- Plant construction
- Construction of power units

Material

Body:	steel, black oxide
Rotating plate:	steel, black oxide
Body balancer:	aluminium
Body indexing:	aluminium
Indexing mechanism:	steel, hardened

Fixation

To fix *modulog* modules or components of the user, the tilting module has a 140 x 140 interface in the flange plate and the body.

Important notes

The pneumatic balancer requires compressed air supply.

Description

The tilting module KMB 100 with pedal-operated indexing offers the possibility of easy manual tilting of heavy components by ±90° and their reliable fixing.

The tilting module is equipped with a pneumatic balancer that compensates almost completely generated torques during tilting. Therefore only little forces are required for tilting of the component part.

The balancer is adapted to the weight of the component part by a pneumatic pressure reducing valve.

The operating unit of the indexing is connected by a 2 m long hydraulic hose to the tilting module.

This flexible connection allows the individual placement of the operating unit at the most favourable ergonomic position.

The standard indexing positions are set to 0° and 90°. Other engagement positions are available on request (e.g. 0, 30, 45, 60 and 90 degrees).

The tilting module is equipped with a hydraulic brake for maximum operating safety.

Operation

The tilting module does not have any operating elements. The tilting operation is effected manually directly at the component part or at the assembly fixture.

The indexing is operated by a foot pedal. By operating the foot pedal by 35° the index is released and the component part or the fixture can be tilted.

If the foot pedal is not operated, the index bolt engages automatically into the next indexing position.

The operation with a foot pedal guarantees that the operator always has both hands free.

modulog

Tilting module

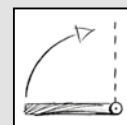

Part-no. 65070190 OIL

Technical data

Max. load:	1,000 N
Max. torque:	500 Nm
Max. balanceable torque:	180 Nm

Operation

- Manual



Indexing

Indexing angle: 0 / 90°
Operation by pedal



Combinable with the modules

- Rotating module - vertical axis DMV 1000 as per data sheet M 3.101
- Lifting modules as per data sheet M 4.XXX



modulog interfaces

- Flange plate 140 x 140 - M10
- Body: 140 x 140 - Ø 10.5 mm

Functional principle

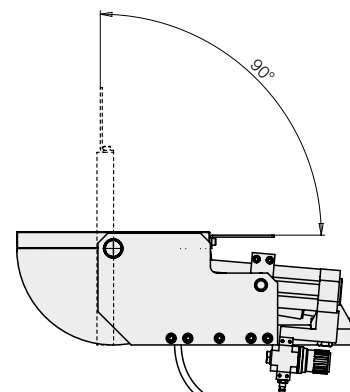

Technical data Dimensions

Dimensions

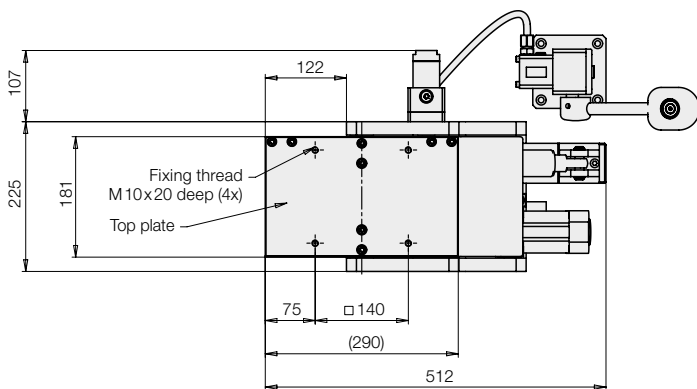
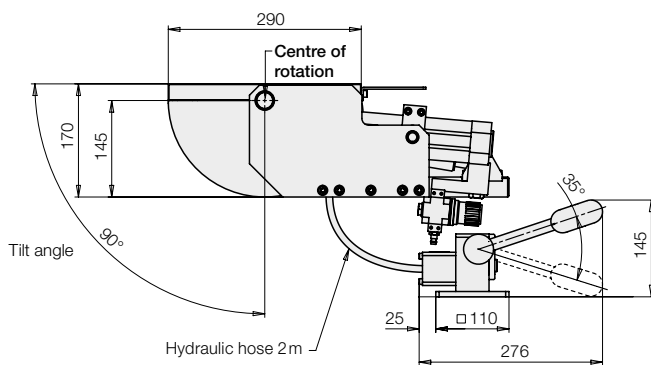
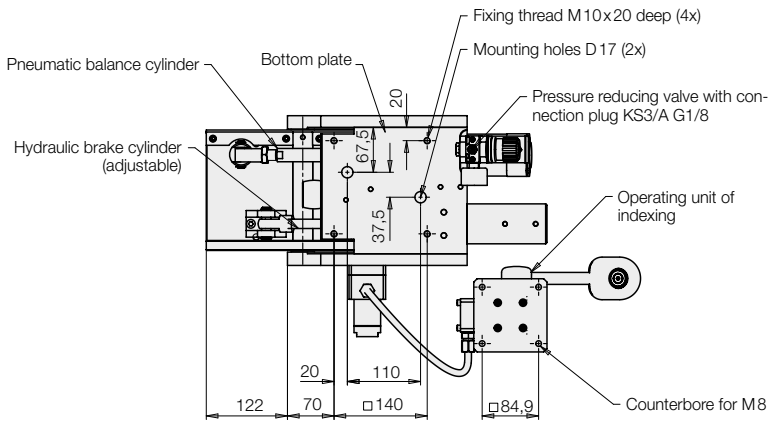

Application example



Tilting module KMB 100 – mounted on lifting module Shop-Floor

Delivery

The tilting module and the indexing unit are delivered as a completely assembled unit ready for use.

Important notes

The adjusted compensation weight or torque is always effective. Therefore the tilting module must only be loaded and unloaded in horizontal position. In tilted position, unlocking must not be made without load.

For the pneumatic connection a compressed air coupling ND 7.2 is recommended.

The fixing screws M10 are not included in our delivery.

The tilting module is designed for applications within closed rooms.

Part-no. 65070190OIL

Technical data

Operation:	manual
Tilting angle:	0° and 90°
Balancer:	pneumatic, max. balanceable torque 180 Nm (with regard to the centre of rotation) compressed air 0 to 10 bar (adjusting range)
Indexing:	hydro-mechanical, operation with foot pedal indexing positions 0° / 90° positioning precision $\lt; \pm 1^\circ$
Weight:	55 kg

Maximum admissible load

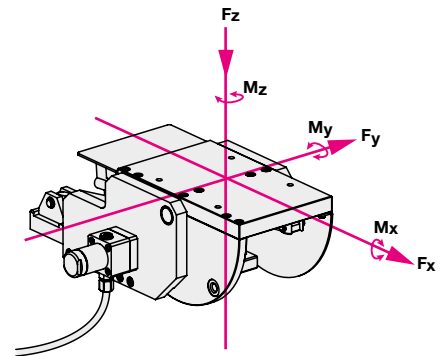

Maximum admissible forces:

- $F_x = \pm 1,000 \text{ N}$
- $F_y = \pm 1,000 \text{ N}$
- $F_z = + 1,000 \text{ N}$

Maximum admissible torques

- $M_x \text{ or } M_z = 500 \text{ Nm}$
- $M_y = 500 \text{ Nm}$ (for the engaged mode)
- $M_y = 180 \text{ Nm}$ (for the engaged mode)

The total of all occurring forces or torques must not exceed the highest single value.

Balanceable torque

The pneumatic balancer can balance torques up to 180 Nm.

The torque, which will be balanced, depends on the existing pneumatic pressure that can be adjusted at the pneumatic pressure reducing valve of the balancer.

Range of adjustment: 0 to 10 bar